

Item	Qty.	Description
1	1	37.5" Q914 Vertical Extrusion w/ Hinges
2	1	37.5" Q914 Vertical Extrusion w/ Door Stop
3	2	32.5" Q914 Vertical Extrusion
4	2	37.5" Q914 Vertical Extrusion
5	5	13.5" Z45 Horizontal Extrusion
6	2	14.5" Z45 Horizontal Extrusion
7	2	14.5" Z45 Horizontal Extrusion

- Steps:**
- 1) Attach verticals [1 to 3] and [2 to 3]. See **Extrusion Connector** detail.
 - 2) Attach front assembly [4] [5] and infill to back assembly [1/3] [2/3] and [5] with [6] [7] and infills.
 - 3) Connect door to vertical [2]. See **Door Connection** detail.
 - 4) Connect shelf supports to Velcro on inside of assembled stand, then set shelf on top of supports.
 - 5) Lock counter top to horizontals [7]. See **Counter Top Attachment** detail.
 - 6) Attach monitor mount to verticals [3]. See **Monitor Mount Attachment** detail.
 - 7) Attach literature holders to verticals [1] and [2]. See **Literature Holder Attachment** detail.

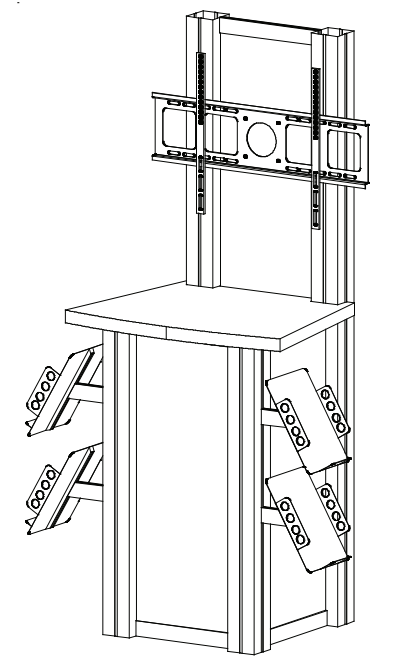

Completed Stand Assembly

When Packing:
 Keep extrusions [1] [2] and [5] with door assembled.
 Keep extrusions [4] and [5] with infill assembled.
 Keep V15 connectors attached to extrusions [1] and [2].

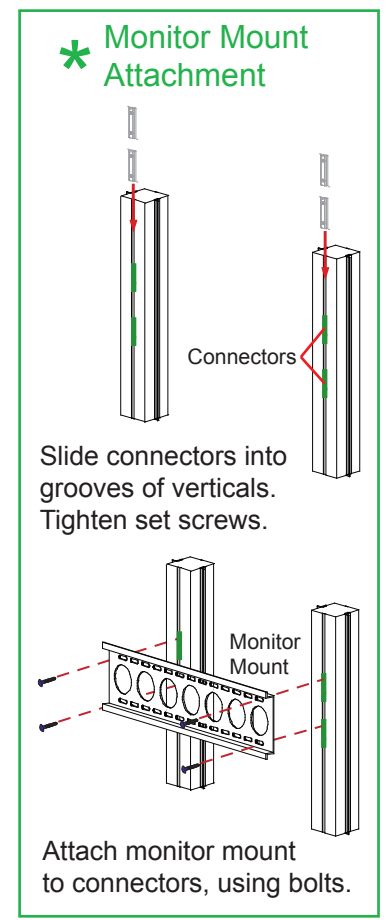
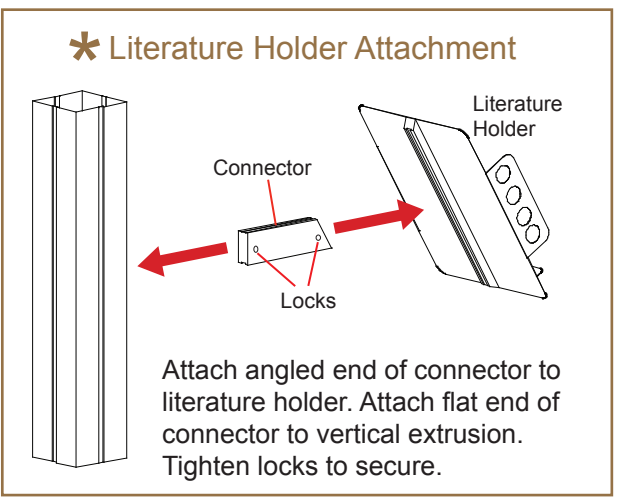
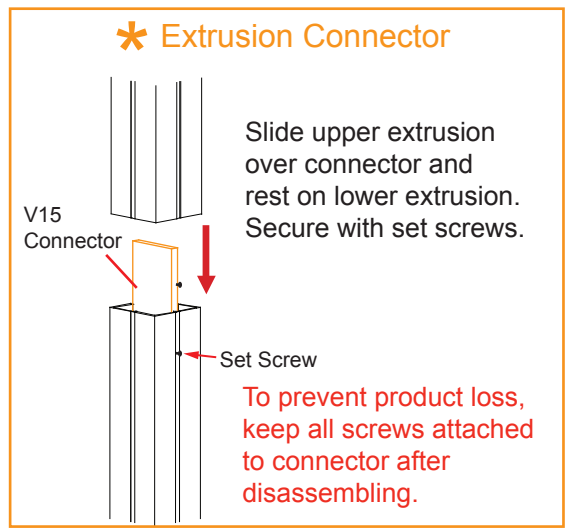
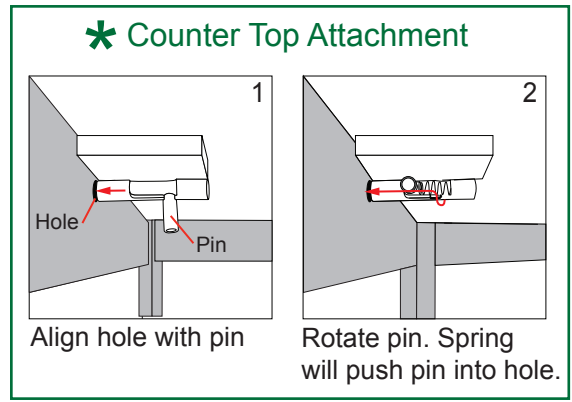
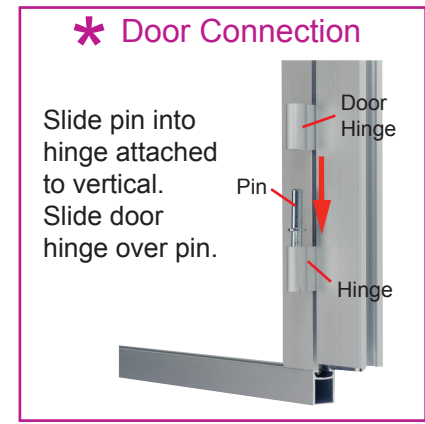
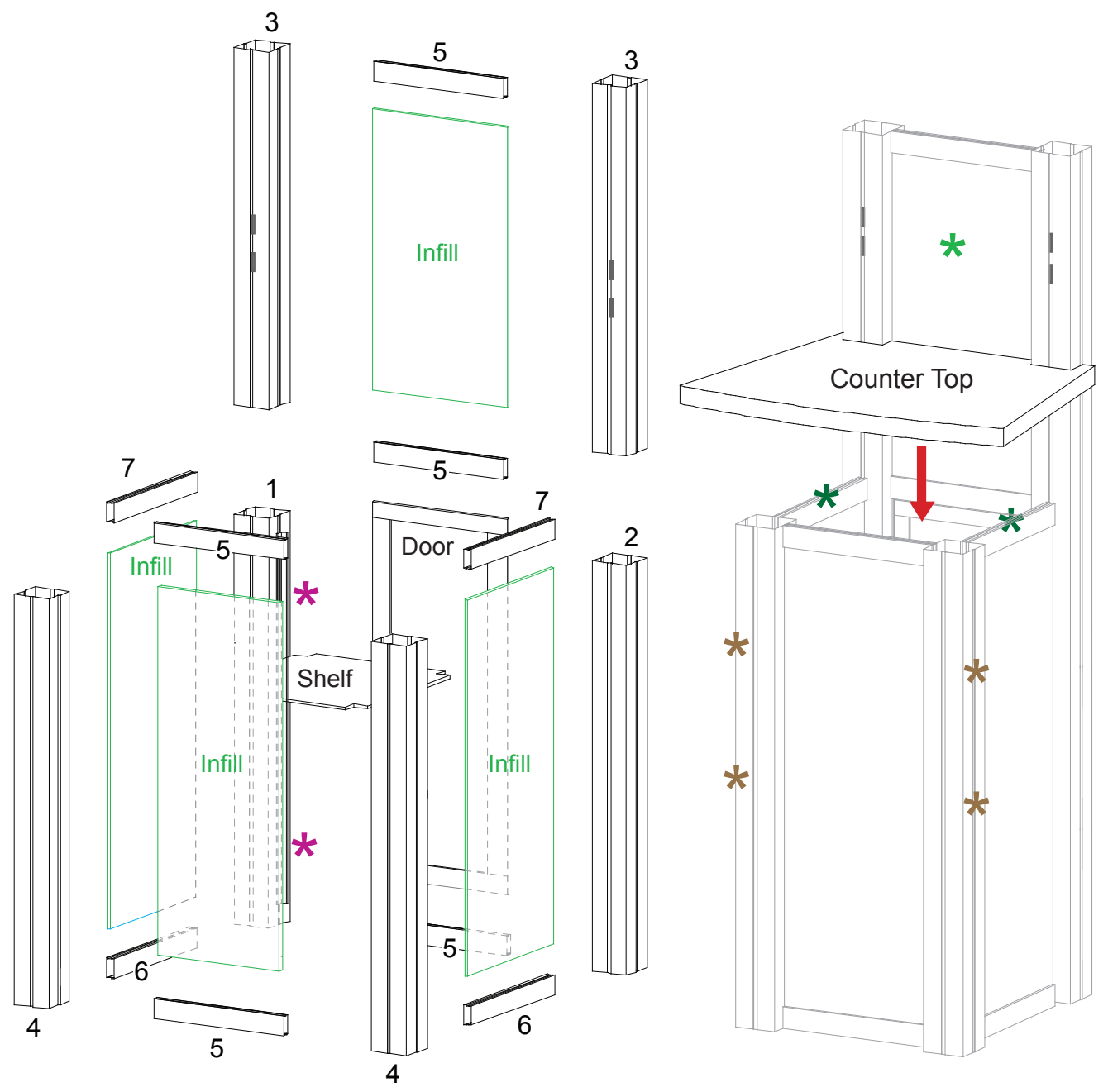

General Setup Instructions

- Read entire setup instruction manual prior to unpacking parts and pieces.
- The setup instructions are created specifically for this configuration.
- Setup instructions are laid out sequentially in steps, including exploded views with detailed explanation for assembly.

Cleaning & Packing

- For Cleaning Metal, Plex, & Laminate Parts: Use a **MILD NON-ABRASIVE** cleanser and soft cloth/paper towel to clean all surfaces.
- Keep exhibit components away from heat and prolonged sun exposure. **Heat and UV exposure will warp and fade components.**
- Retain all provided Packing Materials. All provided packing materials are for ease of repacking & component protection.

Disassembly

- For loss prevention, tighten all set screws and locks during disassembly.

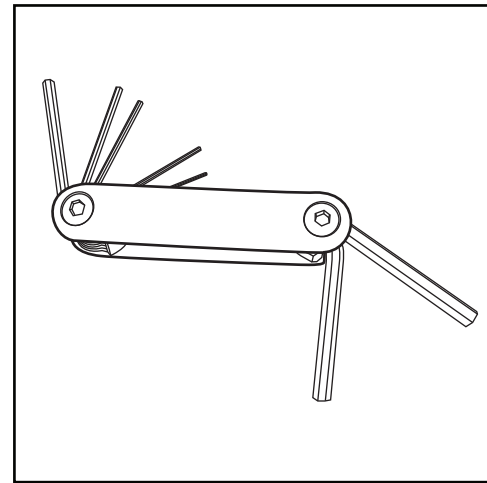

Hex Tool - Essential for Assembly

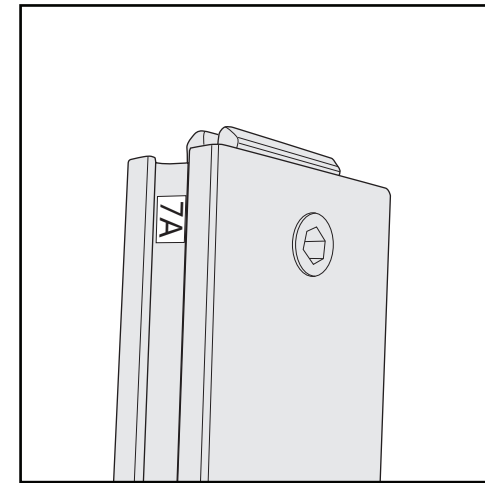

Part Identification - Numbering

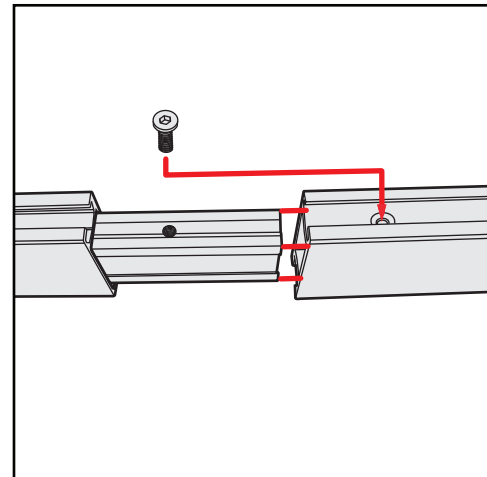

Spline Connection

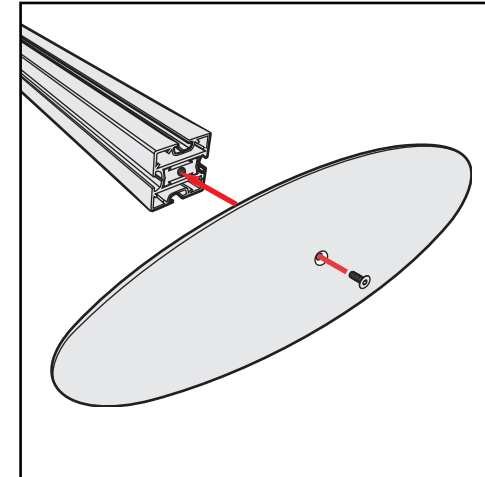

Base Plate & Extrusion Connection

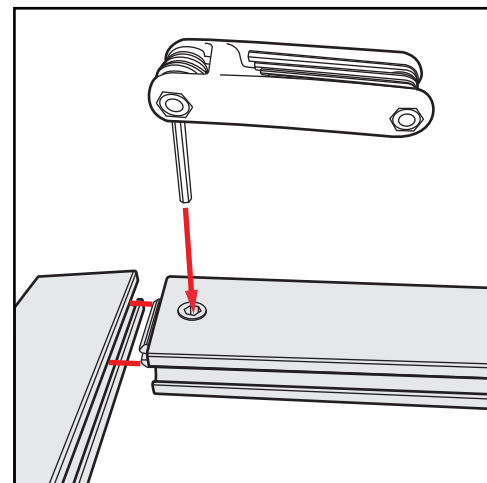

Extrusion & Lock Connection

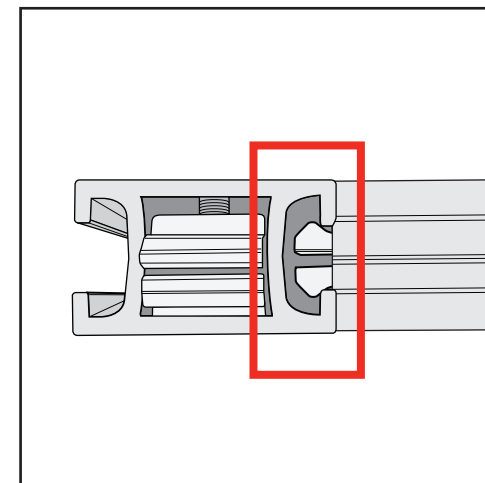

Engaged Lock



WARNING



DO NOT USE POWER TOOLS



LADDERS OR LIFTS
MAY BE REQUIRED



ALL CONNECTIONS MUST
BE TIGHTLY SECURED